



1080 CF / 36 CF ST / 36 CF Pier Power Heat Duct Wiring Kit (sku 94400995)

Overview

This kit is required when using the optional power heat duct (sku 98500769) with the 1080 CF, 36 CF ST, or 36 CF Pier gas fireplace. The instructions below detail installation of this wiring kit. Additional wiring is required at the time of installation to hook up the remote blower.

Packing List

- Power Hook-up Harness (has 2 molex connectors)
- Snap Disk Harness (1 molex connector and 2 quick-connects)
- Power Lead (used only for Method B)
- Molex Power Lead (used only for Method B)
- (3) Wire Nuts (used only for Method B)

Wiring Schematic – Method A

This method utilizes an external rheostat to control the power heat duct. This type of installation is recommended when placing the power heat duct in a separate room from the fireplace.

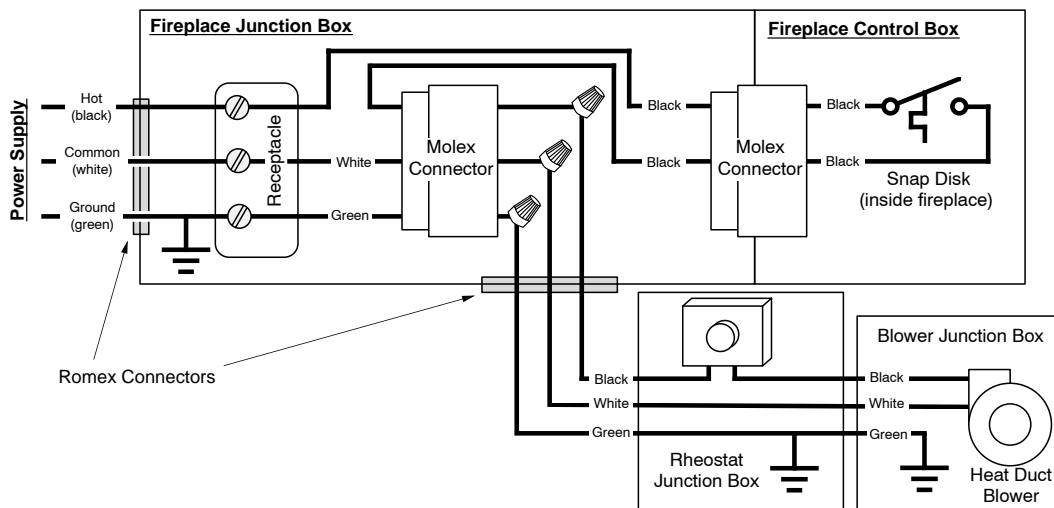

Wiring Schematic – Method B (for fireplaces with ALPHA Controllers ONLY)

This method uses the alpha remote control to control the blower. This type of installation is only recommended when placing the power heat duct in the same room as the fireplace.

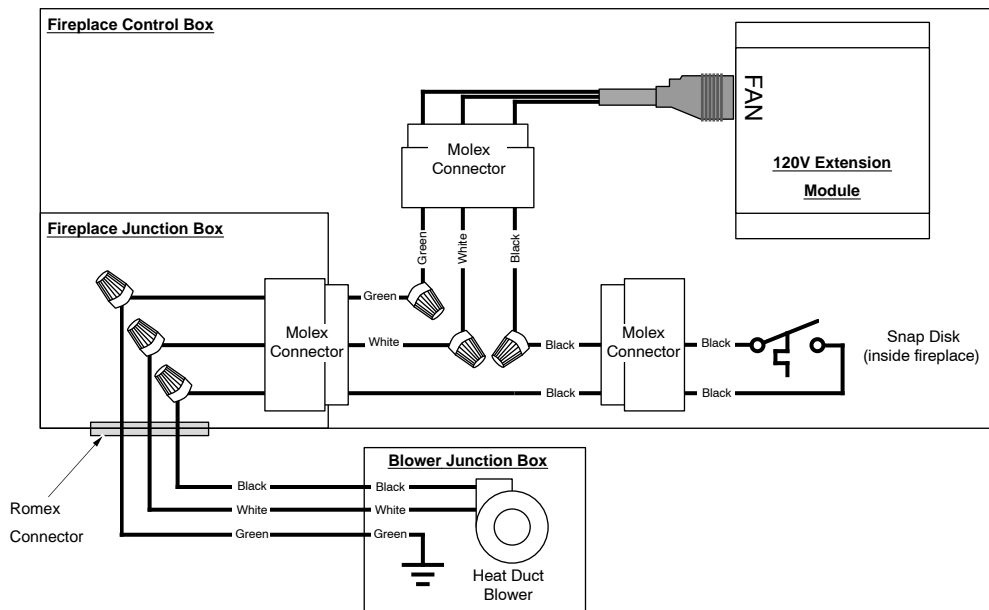



1080 CF / 36 CF ST / 36 CF Pier Power Heat Duct Wiring Kit (sku 94400995)

Installation – Method A

WARNING: All electrical connections must be made by a qualified installer and must meet all local codes.

WARNING: Make sure all power to the appliance has been turned off prior to installation (disable the breaker).

1. Remove the cover plate from the cover box on the left side of the fireplace. Locate the molex connector with 2 black wires on the power hook-up harness (not the one with 3 wires). Insert the molex connector into the slot next to the receptacle (see illustration below). Make sure the molex connector has fully locked into place.

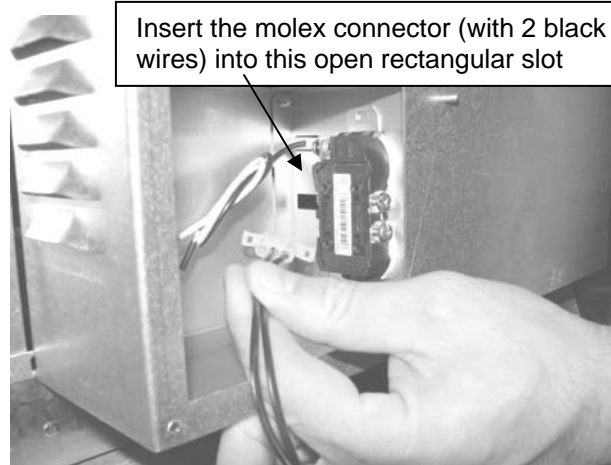
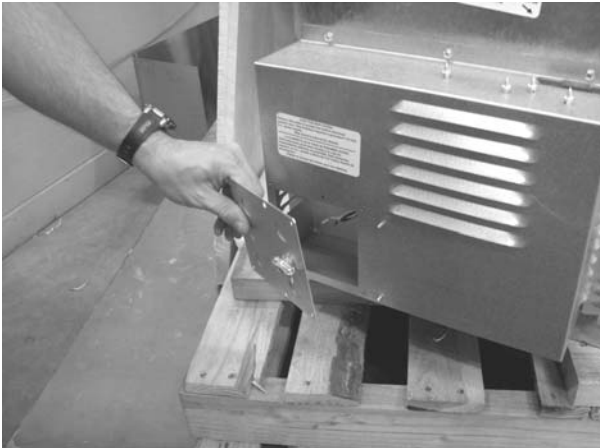

1080 CF / 36 CF ST / 36 CF Pier Power Heat Duct Wiring Kit (sku 94400995)

Installation – Method A (continued)

2. Attach the three wires from the power hook-up harness to the back of the receptacle. These wires attach to the screw-connections on the back of the receptacle. Make sure to connect the black to the hot, the white to the common, and the green to grounding post.

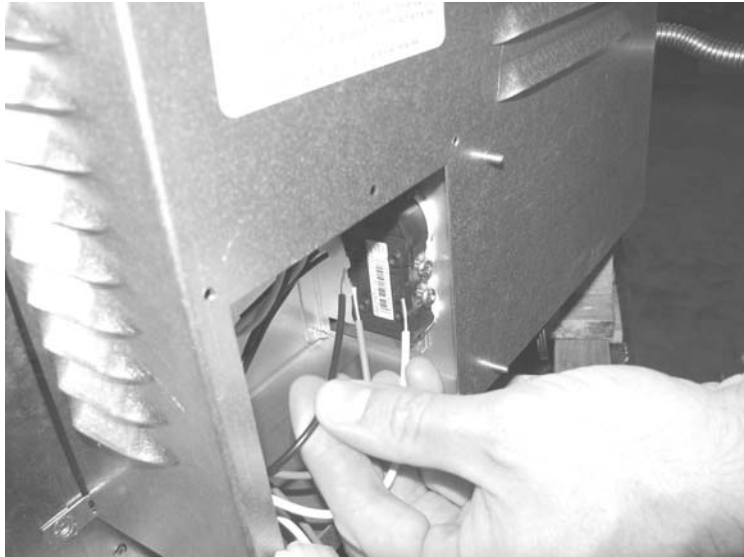

3. Remove the cover box from the fireplace. Attach the snap disk harness to the molex connector attached in step 1.

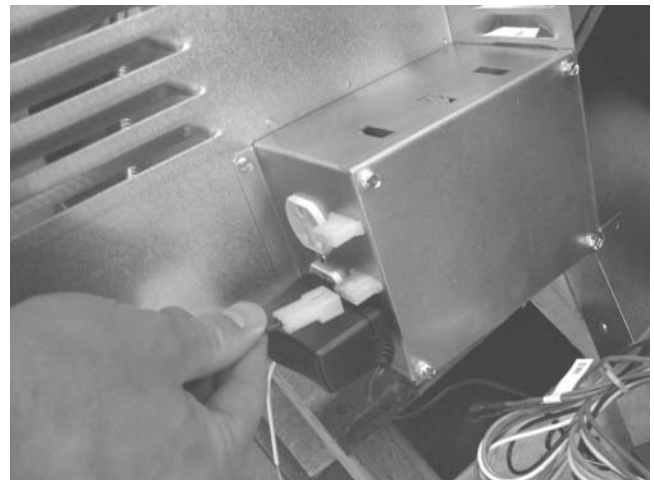

Installation – Method A (continued)

4. Attach the snap disk harness to the snap disk (included with the power heat duct).



5. Slide the snap disk (included with the power heat duct) into position on the fireplace.

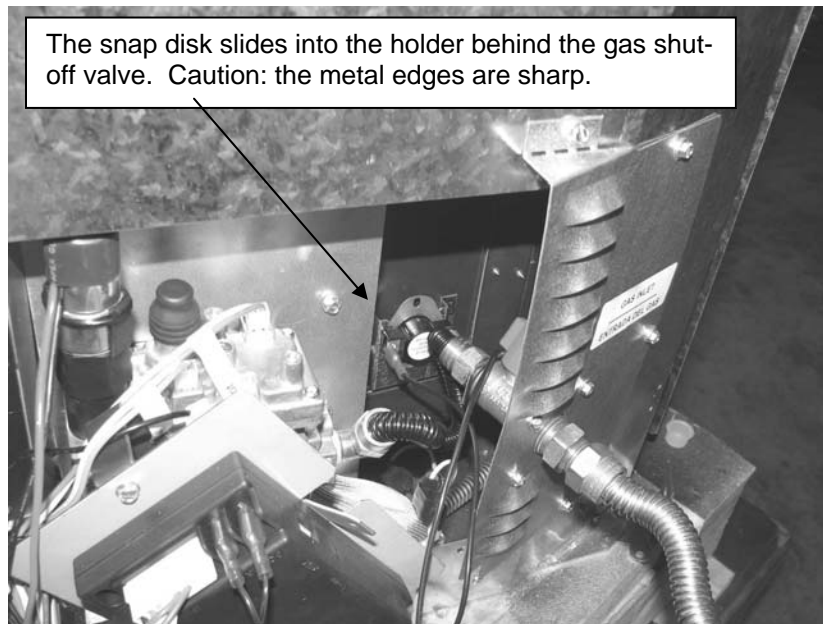

6. Replace the cover box, making sure no wiring contacts the firebox wall.
7. The power heat duct includes instructions for completing the installation. Follow the instructions for the 36DV / 44 DVXXL / 864 HH and attach the molex connector (included with the power heat duct) to the power hook-up harness inside the junction box on the 1080 CF fireplace.

Installation – Method B

WARNING: All electrical connections must be made by a qualified installer and must meet all local codes.

WARNING: Make sure all power to the appliance has been turned off prior to installation (disable the breaker).

1. Prepare the wiring harness that is placed inside the fireplace control box (see the wiring harness on page 1 and the photo below).

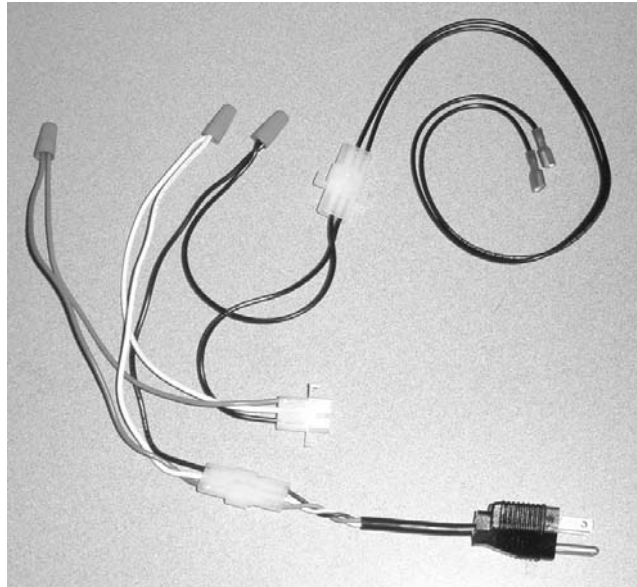

2. Snap the molex connector on the wiring harness into the junction box (see photo below).

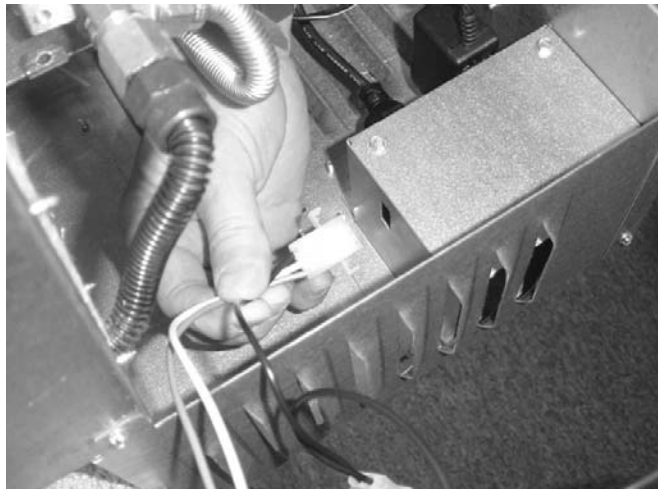

Installation – Method B (continued)

3. Plug the power cord into the outlet labeled “FAN” on the 120V Extension Module (see photo below).

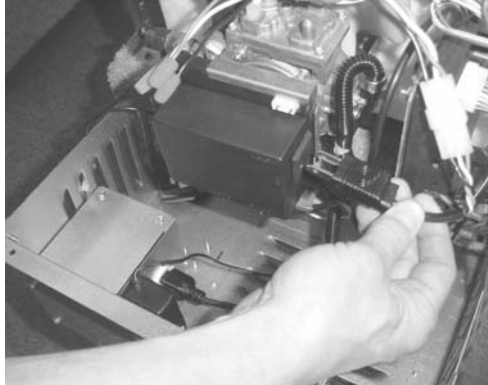

4. Attach the snap disk harness to the snap disk (included with the power heat duct).

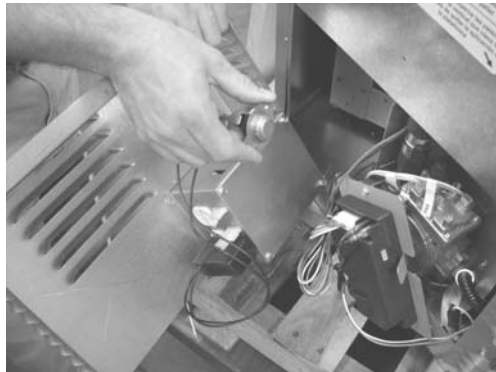

5. Slide the snap disk (included with the power heat duct) into position on the fireplace.

The snap disk slides into the holder behind the gas shut-off valve. Caution: the metal edges are sharp.

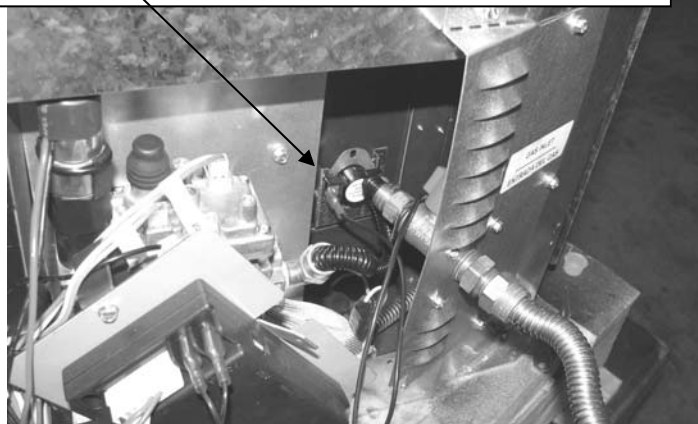

6. Replace the cover box, making sure no wiring contacts the firebox wall.
7. The power heat duct includes instructions for completing the installation. Follow the instructions for the 36DV / 44 DVXXL / 864 HH and attach the molex connector (included with the power heat duct) to the power hook-up harness inside the junction box on the 1080 CF fireplace.